

CANDIDATE
NAME

CENTRE
NUMBER

--	--	--	--	--

CANDIDATE
NUMBER

--	--	--	--

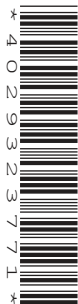

COMBINED SCIENCE

Paper 4 (Extended)

0653/41

May/June 2017

1 hour 15 minutes

Candidates answer on the Question Paper.

No Additional Materials are required.

READ THESE INSTRUCTIONS FIRST

Write your Centre number, candidate number and name on all the work you hand in.

Write in dark blue or black pen.

You may use an HB pencil for any diagrams or graphs.

Do not use staples, paper clips, glue or correction fluid.

DO NOT WRITE IN ANY BARCODES.

Answer **all** questions.

Electronic calculators may be used.

You may lose marks if you do not show your working or if you do not use appropriate units.

A copy of the Periodic Table is printed on page 24.

At the end of the examination, fasten all your work securely together.

The number of marks is given in brackets [] at the end of each question or part question.

This document consists of **22** printed pages and **2** blank pages.

- 1 (a) Use lines to connect the box on the left to different boxes on the right to make correct sentences.

One is done for you. The sentence reads 'Flowering plants need oxygen for germination of seeds'.

Draw **three** more lines to make three more correct sentences.

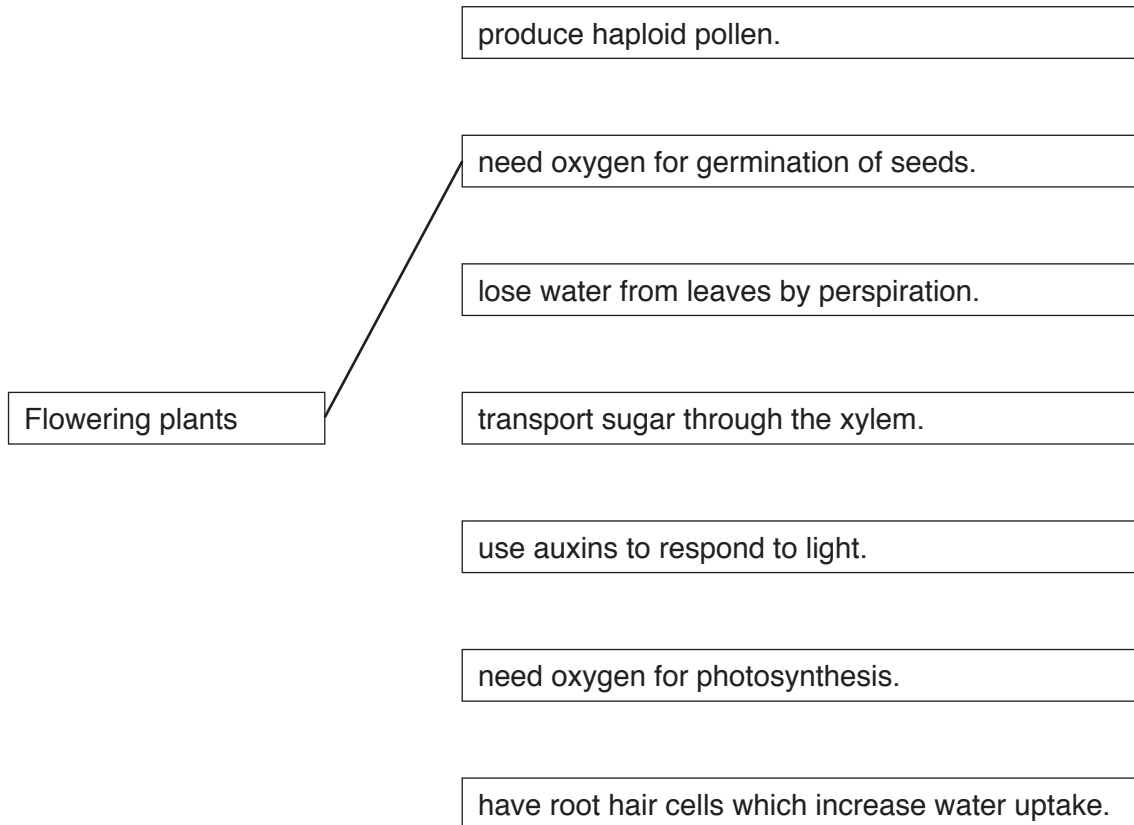

[3]

- (b) Fig. 1.1 is a diagram of a wind-pollinated flower.

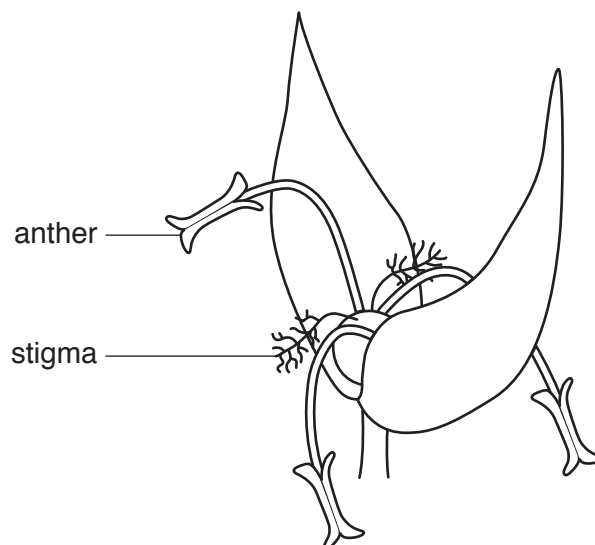

Fig. 1.1

- (i) Describe how the following structures make the flower in Fig. 1.1 suitable for wind-pollination.

the anthers

.....
.....
.....

the stigmas

.....
.....
.....

[2]

- (ii) Suggest **one** reason why wind-pollinated crops are grown close together by farmers.

.....
..... [1]

- (c) The growth of crops can be reduced by acid rain.

- (i) Describe how burning fossil fuels can lead to acid rain.

.....
.....
.....
..... [2]

- (ii) Suggest how acid rain reduces the rate of growth of crops.

.....
..... [1]

- 2 (a) Fig. 2.1 is a dot-and-cross diagram to show the outer-shell electrons in a molecule of hydrogen chloride, HCl .

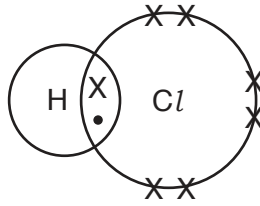

Fig. 2.1

- (i) State the type of chemical bond shown in Fig. 2.1.

..... [1]

- (ii) Draw a dot-and-cross diagram to show the outer-shell electrons in a molecule of methane, CH_4 .

[2]

- (b) (i) Name the **two** products of the complete combustion of methane.

1.

2.

[2]

- (ii) Explain, in terms of energy changes, why methane is used as a fuel.

.....

..... [1]

- (c) Methane is the main constituent of one fossil fuel.

- (i) State the name of this fossil fuel.

..... [1]

- (ii) State the names of **two other** fossil fuels.

..... and [1]

- 3 Fig. 3.1 shows a wind surfer on a surf board, driven by the wind, sailing at a constant speed across the sea. The arrows labelled **A**, **B**, **C** and **D** show the forces acting on the surf board.

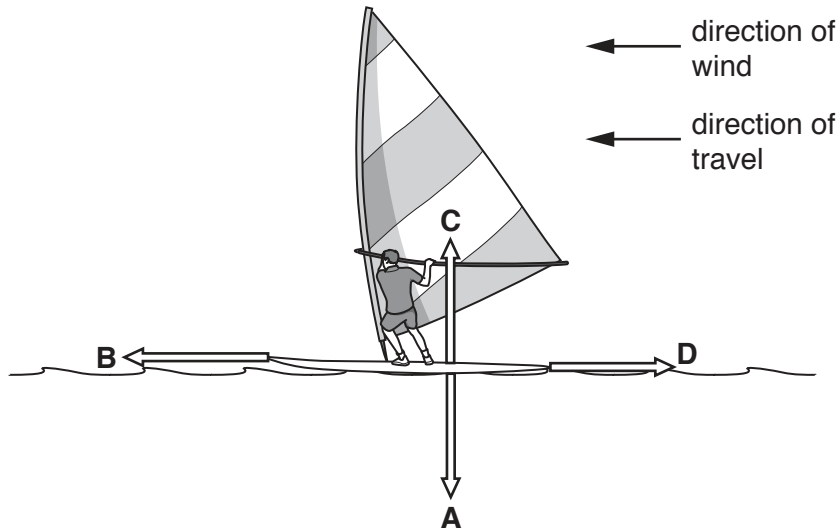

Fig. 3.1

- (a) (i) State which letter, **A**, **B**, **C**, or **D** corresponds to

1. frictional force

2. upthrust

[1]

- (ii) Force **A** is measured and found to be 1200 N.

State whether force **C** is 1200 N or has a different value.

Give a reason for your answer.

.....
 [1]

(b) The surf board travels at a constant speed of 2 m/s.

The wind speed then increases, and the surf board moves with an acceleration that is not constant until the surf board reaches a constant speed of 4.5 m/s after 10 s.

On Fig. 3.2 sketch the shape of the speed-time graph of the motion of the surf board from the time the wind speed increases until just after the constant speed of 4.5 m/s is achieved.

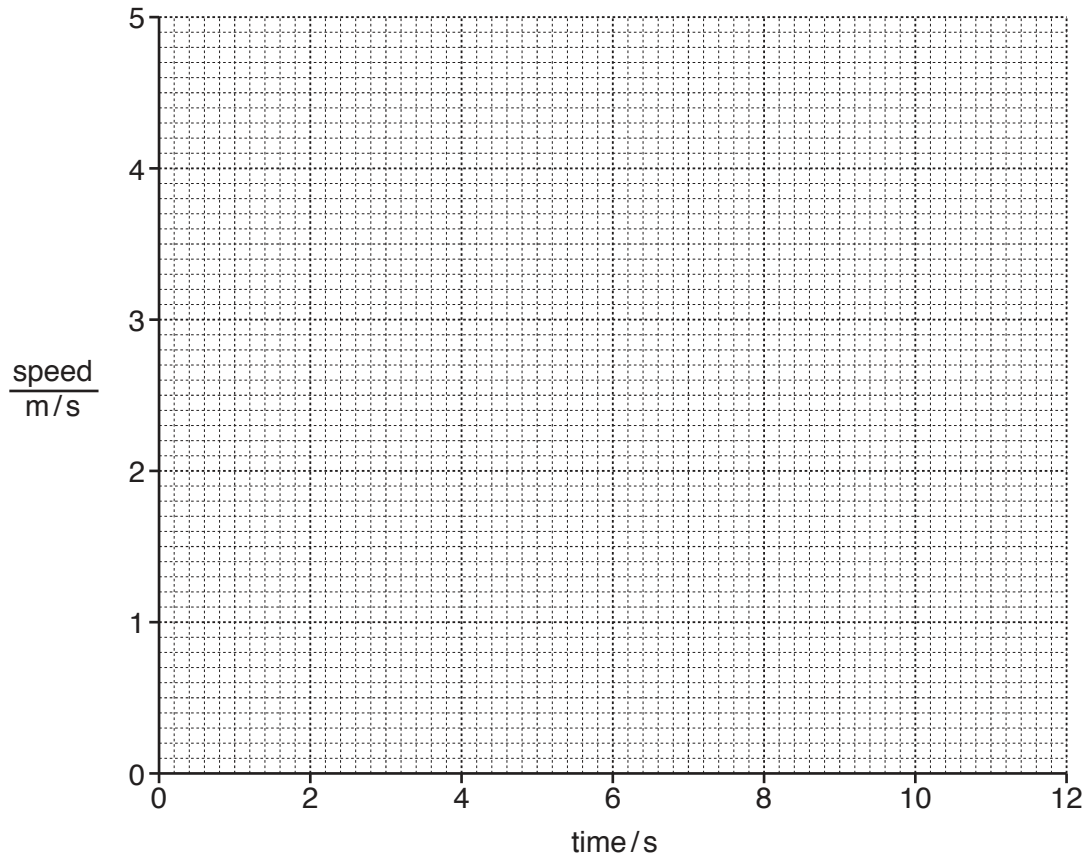

Fig. 3.2

[2]

(c) The kinetic energy of the wind provides the work needed to move the surf board across the sea.

(i) The mass of the surf board and surfer is 120 kg.

Calculate the kinetic energy of the surf board and surfer when they are moving at 3 m/s.

State the formula you use and show your working.

formula

working

kinetic energy = J [2]

(ii) The wind transfers 90 kJ of energy to the surf board when moving it along at 3 m/s for 50 s.

Use the work done by the wind to calculate the driving force of the wind.

State any formula you use and show your working.

formula

working

driving force = N [3]

- 4 (a) Fig. 4.1 shows a drawing of a single-celled organism called *Euglena* as seen using a light microscope.

This organism has features of both plants and animals.

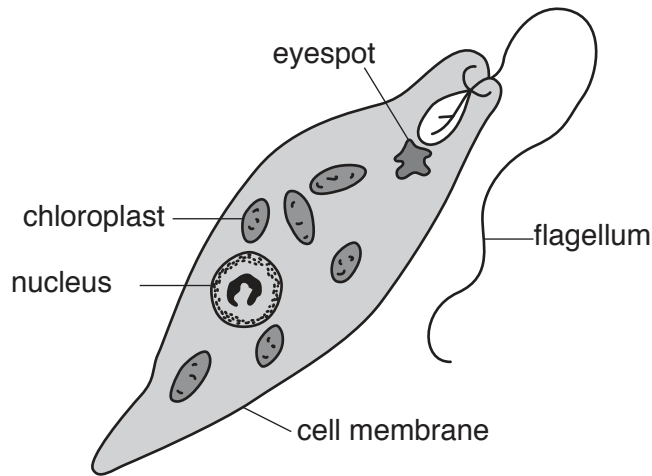

Fig. 4.1

- (i) Chloroplasts are usually found in plant cells.

Describe in detail the function of chloroplasts.

.....

.....

.....

.....

..... [3]

- (ii) Name **one** feature of *Euglena* you would more likely see in an animal than a plant.

Explain your answer.

feature

explanation

.....

.....

[2]

(b) Fig. 4.2 shows an aquatic food web. Phytoplankton are microscopic plants that float on the surface of the water. Zooplankton are very small animals.

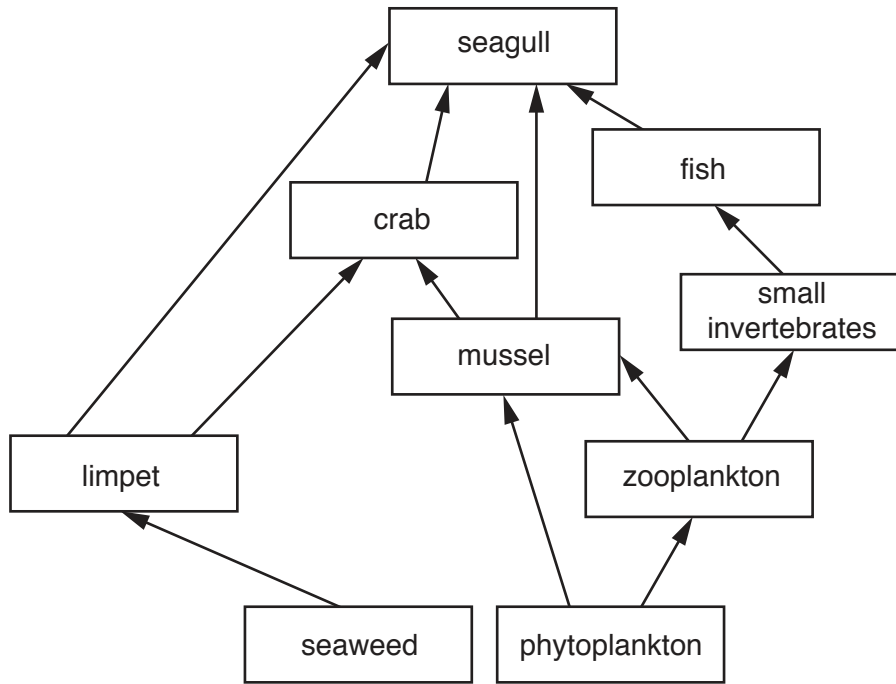

Fig. 4.2

(i) Use Fig. 4.2 to draw a food chain containing five organisms, including the crab.

[2]

(ii) The chemical energy contained in the producers is transferred through the food web to the seagull as shown in Fig. 4.2.

Suggest why the seagull gets more energy transferred from the phytoplankton by eating mussels rather than fish. Explain your answer in detail.

.....

.....

.....

.....

.....

.....

..... [3]

- 5 A student investigates the reaction between dilute sulfuric acid and excess copper(II) carbonate powder.

The apparatus she uses is shown in Fig. 5.1.

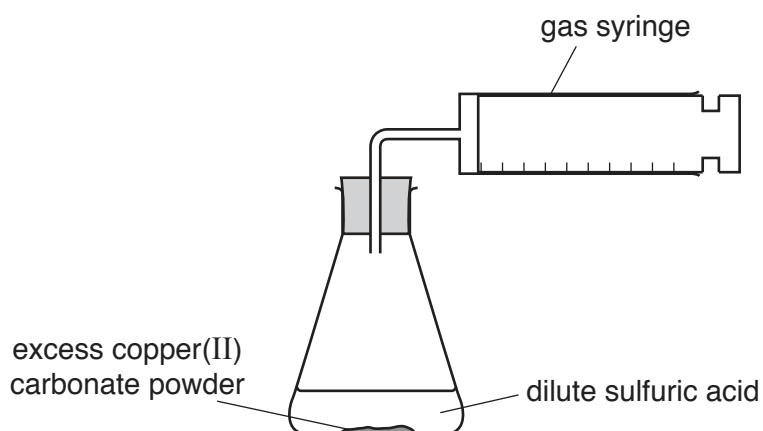

Fig. 5.1

The reaction produces a gas which is collected in the gas syringe.

A salt and another compound are also produced.

- (a) (i) Describe the pH change, if any, of the reaction mixture.

Name this type of reaction.

pH change

reaction type

[2]

- (ii) Complete the balanced symbol equation for the reaction between dilute sulfuric acid and copper(II) carbonate.



(b) Copper(II) carbonate is insoluble in water.

The salt which is produced in this reaction is soluble in water.

Suggest a method of making pure, dry crystals of this salt from the mixture that is left after the reaction is complete.

.....

.....

.....

..... [2]

(c) The student records the volume of gas in the syringe for 10 minutes.

Her results are shown in Fig. 5.2.

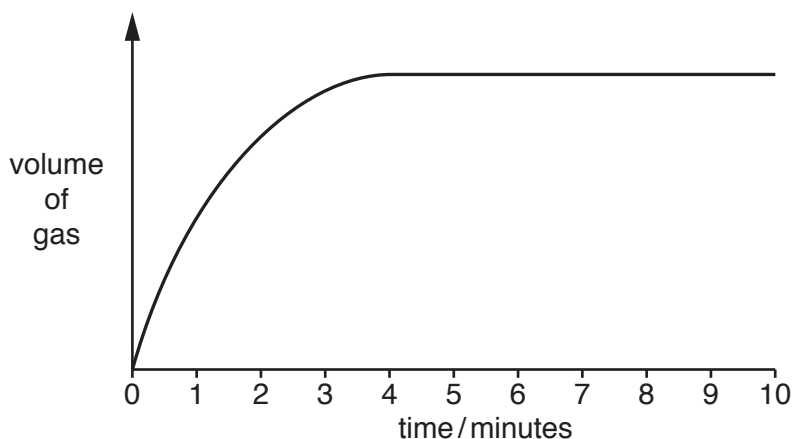

Fig. 5.2

Describe how the shape of the graph shows the change in the rate of the reaction.

.....

.....

.....

..... [2]

(d) She repeats the experiment using the same volume of less concentrated sulfuric acid.

(i) Draw a line on Fig. 5.2 to show her results. [2]

(ii) Explain, in terms of particle collisions, the effect of using less concentrated sulfuric acid on the rate of the reaction.

.....

..... [1]

6 Fig. 6.1 shows a man standing in the sea on a sunny day.

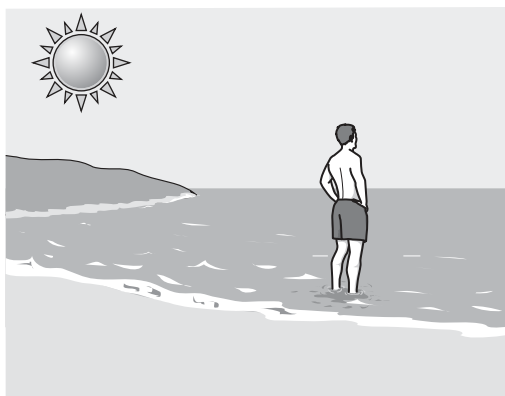

Fig. 6.1

(a) (i) The man says that his back is getting too hot in the Sun.

Explain why wearing a white shirt can prevent the temperature of his back from increasing.

.....

 [2]

(ii) The temperature of the man's body is 37°C. The temperature of the sea water is 15°C.

Explain why the man says that the water feels cold to his feet.

.....

 [2]

(iii) The man walks out of the sea, and his wet feet slowly become dry. He says that his feet get colder as they dry.

Complete the sentences below that explain in terms of the movement of molecules why his feet get colder as they dry.

The water molecules escape from the surface of the water on his feet.

This means that the remaining water molecules have less

..... so the remaining water on his feet is at a lower [2]

- (b) Fig. 6.2 shows a man spear fishing. He sees a fish in the sea in front of him. He says that the fish appears to be near the surface.

The man thinks the fish is at point **F** on Fig. 6.2.

Draw a ray diagram on Fig. 6.2 to show where the fish really is. Mark this point with a letter **X**.

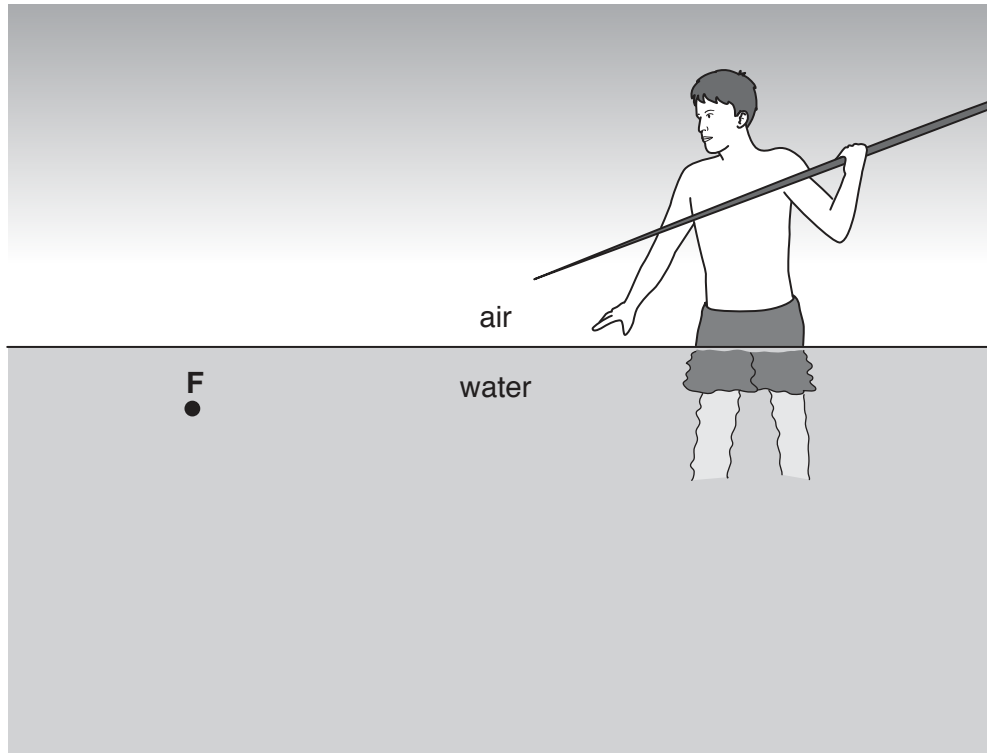

Fig. 6.2

[2]

- (c) The man cooks a fish in a microwave oven.

- (i) On Fig. 6.3 place microwaves in their correct position in the incomplete electromagnetic spectrum.

gamma rays			visible light			radio waves
------------	--	--	---------------	--	--	-------------

Fig. 6.3

[1]

- (ii) Microwaves travel at a speed of 3×10^8 m/s. The wavelength of the microwaves used in the microwave oven is 0.12 m.

Calculate the frequency of the microwaves used.

State the formula you use and show your working.

formula

working

frequency = Hz [2]

- 7 Table 7.1 shows the mass of some of the contents of three foods in a 100 gram sample of each food.

Table 7.1

food	number of grams in the 100 gram food sample			
	fat	carbohydrate	protein	water
bread	7	60	13	20
egg	11	1	13	75
milk	3	5	3	89

- (a) The energy for the body provided by one gram of each nutrient is shown below.

fat 37kJ carbohydrate 17kJ protein 17kJ

A student cooked a meal using 200 grams of eggs.

Use the information contained in Table 7.1 to calculate the energy provided by the 200 grams of eggs.

Show your working.

energy provided = kJ [2]

- (b) A person has a family history of coronary heart disease and it is likely that he will develop the condition too. State which food listed in Table 7.1 he should avoid.

Explain your answer.

food

explanation

.....

.....

[1]

(c) (i) The energy from food is released by respiration.

Complete the balanced symbol equation for respiration.

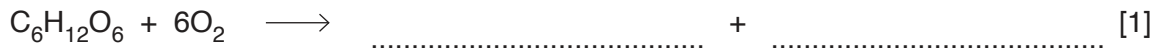

(ii) Describe how oxygen is transported in the blood.

.....

 [2]

(d) Fats, carbohydrates and proteins are made up from large molecules. They have to be broken down by chemical digestion into small molecules.

Name the areas of the alimentary canal where the following processes occur.

1. chemical digestion

..... and

and

2. absorption

..... [2]

Please turn over for Question 8

- 8 (a) Use the Periodic Table on page 24 to determine the electronic structure of an aluminium atom.

..... [1]

- (b) Aluminium is extracted from aluminium oxide by electrolysis, as shown in Fig. 8.1.

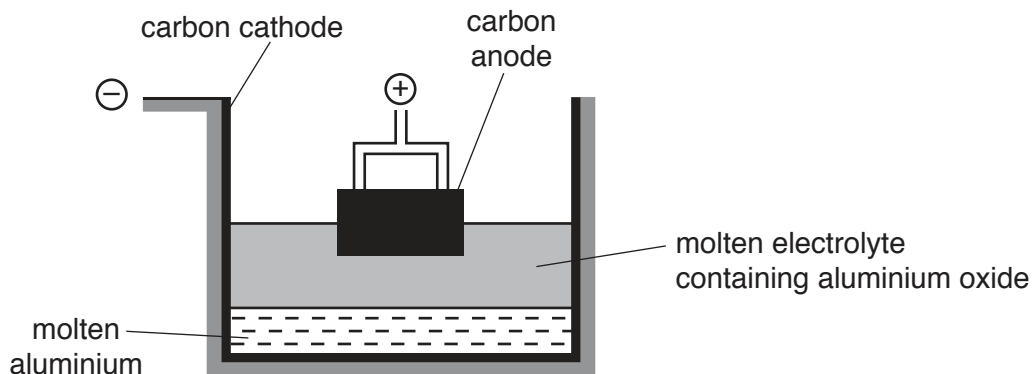

Fig. 8.1

Aluminium oxide, Al_2O_3 , contains aluminium ions, Al^{3+} , and oxide ions, O^{2-} .

- (i) Name the product of electrolysis at the anode.

..... [1]

- (ii) Describe, in terms of atoms, ions and electrons, the reaction that takes place at the cathode.

.....

 [2]

- (c) Iron is extracted from iron(III) oxide in a blast furnace.

- (i) Name a substance that reduces iron(III) oxide in this process.

..... [1]

- (ii) Explain why aluminium cannot be extracted from aluminium oxide in a blast furnace.

.....
 [1]

(d) A student investigates the reactions between aluminium and solutions of metal sulfates.

- (i) When a freshly cleaned piece of aluminium is placed into a solution of magnesium sulfate, no change is seen, as shown in Fig. 8.2.

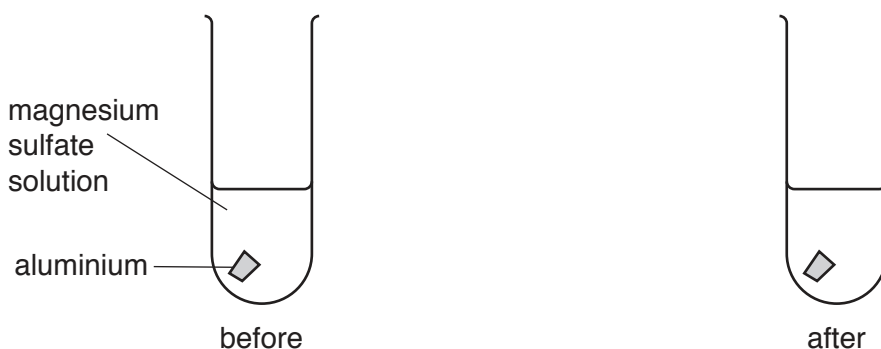

Fig. 8.2

Explain this observation.

.....
 [1]

- (ii) When a freshly cleaned piece of aluminium is placed into a solution of copper(II) sulfate, the surface of the aluminium turns brown and the solution starts to decolourise, as shown in Fig. 8.3.

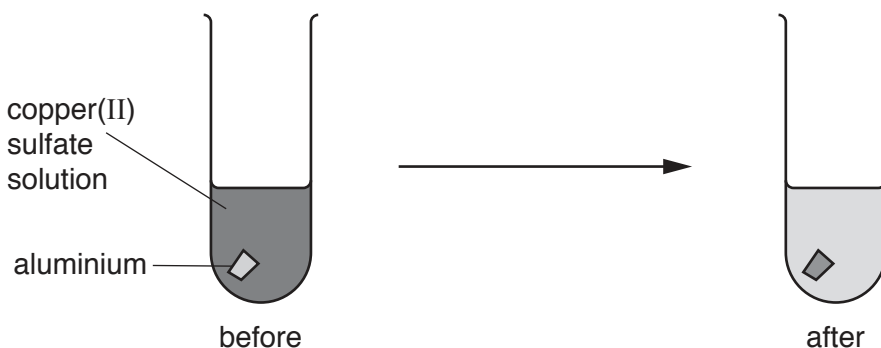

Fig. 8.3

Explain this observation.

.....
 [1]

- 9 Fig 9.1 shows a simple test circuit for testing different materials to see how well they conduct electricity. The material being tested is connected between **X** and **Y**.

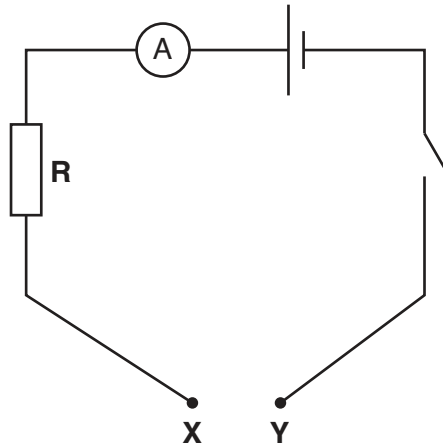

Fig. 9.1

- (a) Name **two** materials other than copper that would be found to be good conductors when tested.

..... and [1]

- (b) A piece of copper wire is connected between **X** and **Y**, and a voltmeter is connected in parallel to resistor **R**.

The ammeter reads 0.5 A. The voltmeter reads 2 V.

Use the formula $R = \frac{V}{I}$ to calculate the resistance of **R**.

Give the unit of your answer.

working

resistance = unit [2]

- (c) Two pieces of wire, **P** and **Q**, with the same length and made of the same alloy, are connected in parallel between **X** and **Y**.

The current in wire **P** is 5A. The ammeter reading is 7A.

- (i) Predict the current in wire **Q**.

Give a reason for your answer.

current in wire **Q** = A

reason

..... [1]

- (ii) Deduce why different currents flow in wires **P** and **Q**. Give reasons for your answer.

.....
.....
.....
..... [2]

The Periodic Table of Elements

		Group												
I	II	III	IV	V	VI	VII	VIII							
3 Li lithium 7	4 Be beryllium 9	1 H hydrogen 1	6 C carbon 12	7 N nitrogen 14	8 O oxygen 16	9 F fluorine 19	2 He helium 4							
11 Na sodium 23	12 Mg magnesium 24	13 Al aluminium 27	14 Si silicon 28	15 P phosphorus 31	16 S sulfur 32	17 Cl chlorine 35.5	18 Ar argon 40							
19 K potassium 39	20 Ca calcium 40	21 Sc scandium 45	22 Ti titanium 48	23 V vanadium 51	24 Cr chromium 52	25 Mn manganese 55	26 Fe iron 56	27 Co cobalt 59	28 Ni nickel 59	29 Cu copper 64	30 Zn zinc 65	36 Kr krypton 84		
37 Rb rubidium 85	38 Sr strontium 88	39 Y yttrium 89	40 Zr zirconium 91	41 Nb niobium 93	42 Mo molybdenum 96	43 Tc technetium —	44 Ru ruthenium 101	45 Rh rhodium 103	46 Pd palladium 106	47 Ag silver 108	48 Cd cadmium 112	54 Xe xenon 131		
55 Cs caesium 133	56 Ba barium 137	57-71 lanthanoids	72 Hf hafnium 178	73 Ta tantalum 181	74 W tungsten 184	75 Re rhenium 186	76 Os osmium 190	77 Ir iridium 192	78 Pt platinum 195	79 Au gold 197	80 Hg mercury 201	86 Rn radon —		
87 Fr francium —	88 Ra radium —	89-103 actinoids	104 Rf rutherfordium —	105 Db dubnium —	106 Sg seaborgium —	107 Bh bohrium —	108 Hs hassium —	109 Mt meitnerium —	110 Ds darmstadtium —	111 Rg roentgenium —	112 Cn copernicium —	—		

Key

atomic number
atomic symbol
name
relative atomic mass

lanthanoids	57 La lanthanum 139	58 Ce cerium 140	59 Pr praseodymium 141	60 Nd neodymium 144	61 Pm promethium —	62 Sm samarium 150	63 Eu europium 152	64 Gd gadolinium 157	65 Tb terbium 159	66 Dy dysprosium 163	67 Ho holmium 165	68 Er erbium 167	69 Tm thulium 169	70 Yb ytterbium 173	71 Lu lutetium 175
actinoids	89 Ac actinium —	90 Th thorium 232	91 Pa protactinium 231	92 U uranium 238	93 Np neptunium —	94 Pu plutonium —	95 Am americium —	96 Cm curium —	97 Bk berkelium —	98 Cf californium —	99 Es einsteinium —	100 Fm fermium —	101 Md mendelevium —	102 No nobelium —	103 Lr lawrencium —

The volume of one mole of any gas is 24 dm³ at room temperature and pressure (r.t.p.)